

Operating instructions

METTLER TOLEDO MultiRange Table and stand scales

METTLER TOLEDO

**KA3s/KA6s/KA15s/KA32s
KB60/KCC150/KCC300**

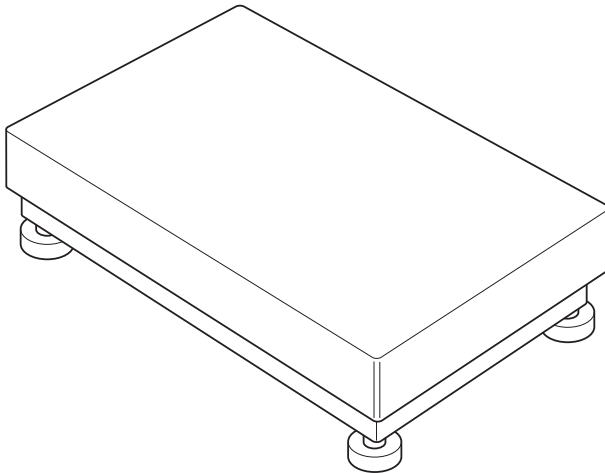
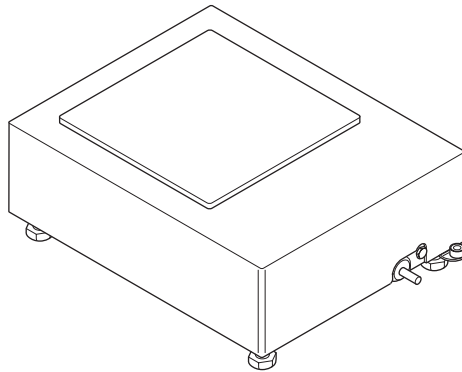

www.mt.com/support

Contents

1	General information	4
2	Safety precautions	4
3	Equipotential bonding	5
4	Removing the transportation lock at the KA3s/6s	6
5	Switching-on/-off routine	6
6	Operating limits	7
7	Cleaning the weighing platform	8
7.1	Notes on cleaning	8
7.2	Subsequent treatment	9
7.3	Cleaning the measuring cell	9
8	Standard accessories	11
9	Technical data of the measuring cell	13
10	Disposal	13

1 General information

The weighing platform is part of a modular system. The associated components, such as terminals, application pacs and the extensive range of accessories, allow you to assemble a weighing system ideally tailored to the needs of your operation.

2 Safety precautions

- ▲ The explosion-protected weighing platform is approved for operation in Zones 2 (gases) and 22 (dusts) hazardous areas. There is an increased danger of injuries and damage when using the weighing platform in hazardous areas! Exercise particular care when using in such areas. The rules for behaviour are based on the concept of "Safe Distribution" established by METTLER TOLEDO.
- ▲ Explosion-protected weighing platforms may be used in hazardous areas of Zones 2 and 22 only in conjunction with weighing terminals that have the appropriate approval and interface specification.
- ▲ The connection cable may not be separated from the weighing terminal while it is energised.
- ▲ Tighten the knurled nut of the IDNet connection cable with 10 Nm of force.

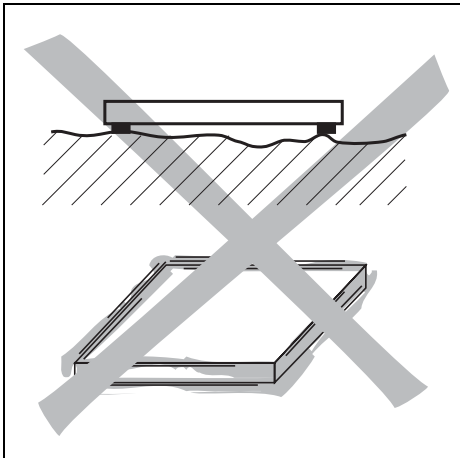

Selecting installation location

- ▲ The foundation must be capable of safely support the weight of the weighing platform at its support points when it carries the maximum load. At the same time, it should be so stable that no vibrations occur during weighing operations. These requirements also apply when the weighing platform is integrated in conveying systems and the like.
- ▲ Ensure that there are no vibrations from machines near the installation site.
- ▲ Ensure that there are no drafts at the installation site.

Ambient conditions

- ▲ Use powder-coated/enamelled weighing platforms only in a dry environment.
- ▲ In a damp environment, in wet operation or when working with chemicals: use stainless-steel weighing platforms.

3 Equipotential bonding

The equipotential bonding must be installed by a professional electrician when using the weighing platform in Zones 2 and 22. METTLER TOLEDO Service only has a monitoring and consulting function here.

- Connect equipotential bonding (PA) of all devices (weighing platform and service terminal) in accordance with the country-specific regulations and standards. In the process, make sure that all device housings are connected to the same potential via the PA terminals.

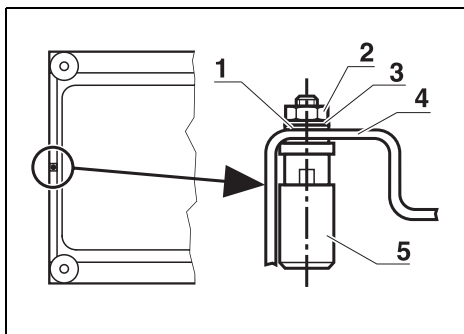

Equipotential bonding with KA...

- (1) Serrated lock washer A 4.3 DIN 6798
- (2) Hexagonal lock nut M4 DIN 934
- (3) Washer 4.3 DIN 125
- (4) Base frame
- (5) Equipotential bonding clamp

Mounting materials are enclosed with the ID7xx, IND690xx or IND4..xx weighing terminal.

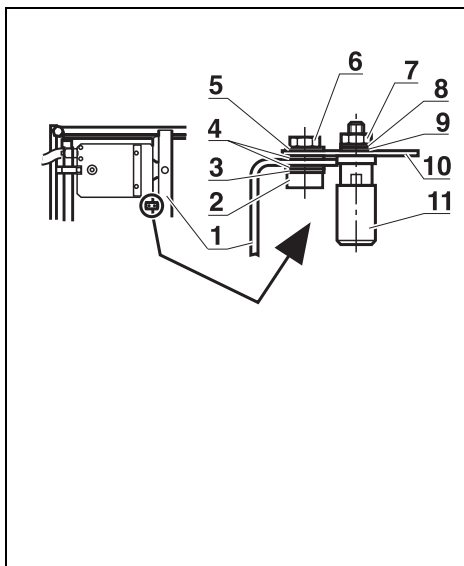

Equipotential bonding with KB..., KCC...

- (1) Frame body
- (2) Fillister head screw M5x12 DIN 912
- (3) Washer 5.3 DIN 125
- (4) Serrated lock washer 5.3 DIN 6798
- (5) Washer 5.3 DIN 125
- (6) Hexagonal lock nut M5 DIN 934
- (7) Hexagonal lock nut M4 DIN 934
- (8) Washer 4.3 DIN 125
- (9) Serrated lock washer A 4.3 DIN 6798
- (10) Potential plate weighing platform
- (11) Equipotential bonding clamp

Mounting materials are enclosed with the ID7xx, IND690xx or IND4..xx weighing terminal.

4 Removing the transportation lock at the KA3s/6s

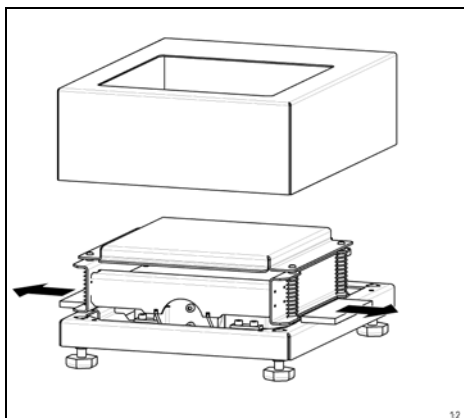

KA3s/6s weighing platforms have a transportation lock in order to protect the weighing cell against damage during transportation.

Removing the transportation lock

- Take off the wind protection and remove the transportation locks outwards.
- Put the wind protection back on.

5 Switching-on/-off routine

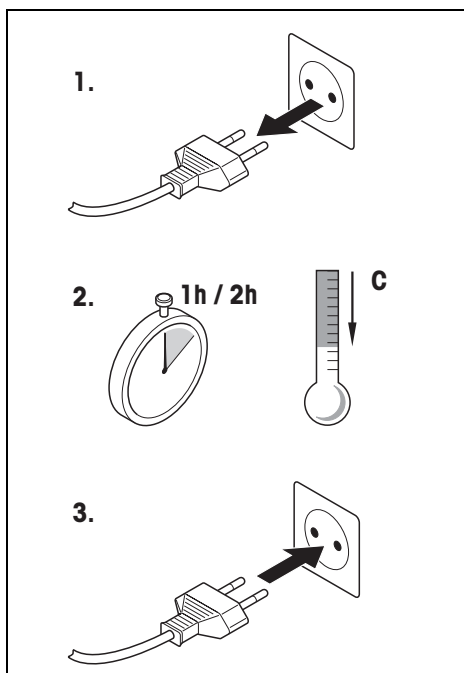

Caution

Possible measured value drift through improper switching on and off!

- The following cooling times must be observed before restarting after a voltage drop or after the weighing system has been switched off:

KA3s/6s	min. 2 h
KA15s/32, KB60,	
KCC150/300	min. 1 h

6 Operating limits

The weighing platform has such a rugged design that no damage should result if the maximum weighing capacity is occasionally exceeded.

The static load-bearing capacity, i.e. the maximum permissible load, is dependent on the type of loading (positions A – C).

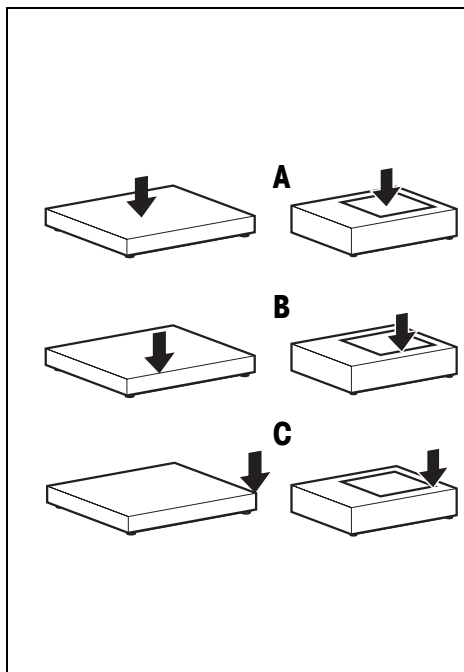

Maximum permissible load

	KA3s KA6s	KA15s	KA32s
A	20 kg	50 kg	50 kg
B	15 kg	40 kg	40 kg
C	10 kg	30 kg	30 kg

	KB60	KCC150 KCC300
A	120 kg	500 kg
B	80 kg	300 kg
C	40 kg	150 kg

A with central load

B with side load

C with one-sided corner load

▲ Falling loads, shocks and lateral impacts must be avoided.

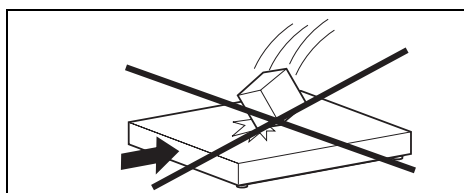

7 Cleaning the weighing platform

Maintenance of the weighing platform is limited to regular cleaning and subsequent oiling. The procedure depends both on the type of surface (powder-coated/enamelled or stainless steel) and on the environmental conditions prevailing at the installation location. Remove dirt and deposits at regular intervals from the outside and inside of the weighing platform.

7.1 Notes on cleaning



CAUTION

Incorrect use of cleaning agents may cause damage to the weighing platform!

- Use only such cleaning agents that do not act on the plastics used in the weighing platform.
- Be particularly careful when cleaning the measuring cell.

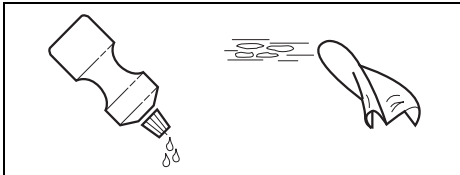

Powder-coated/enamelled version, dry surroundings

- Wipe with a damp cloth.
- Use household cleaning agents.

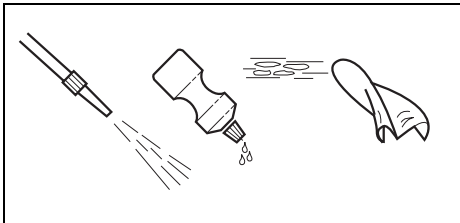

Stainless-steel version

- Wipe with a damp cloth.
- Water jet up to 60 °C.
- Use household cleaning agents.

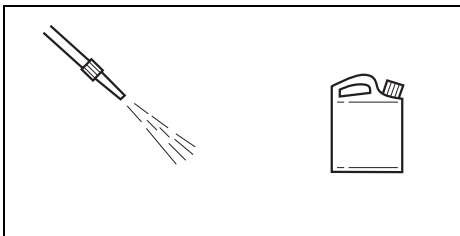

Corrosive surroundings

- Water jet up to 60 °C.
- Remove corrosive substances at regular intervals.
- Only use disinfectants and cleaning agents in accordance with the manufacturer's specifications and instructions.

7.2 Subsequent treatment

Carry out the following subsequent treatment in order to protect the weighing platform:

- Rinse the weighing platform with clear water.
- Dry off the weighing platform with a lint-free cloth.
- Treat the inside and outside of the weighing platform with an oil suitable for foodstuffs.

7.3 Cleaning the measuring cell

The draft guard or load plate has to be removed in order to clean the measuring cell.

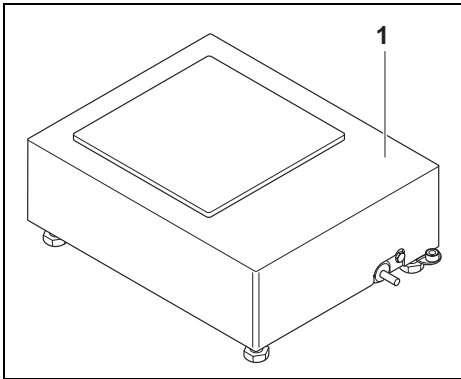

KA3s/KA6s: Removing the draft guard (1)

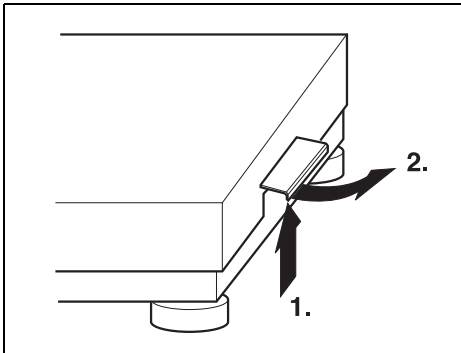

KCC...: Removing the load plate

- Lift both side handles vertically (1.) and then pivot them outward (2.).

Cleaning the measuring cell

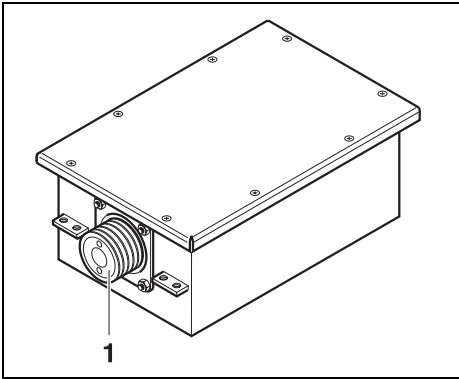

CAUTION

The measuring cell can be damaged!

▲ During cleaning work, never touch, direct an airflow against or spray the rubber diaphragm (1) of the measuring cell.

→ Blow out dirt or rinse out with a moderate water jet.

Placing load plate at KCC weighing platforms

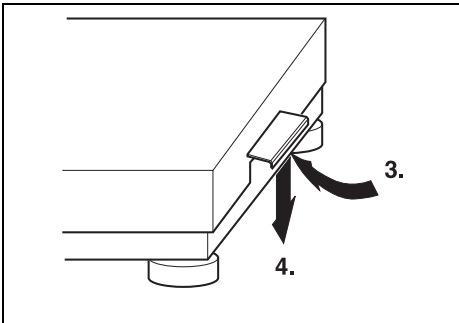

→ After placing the load plate, swing the handles inward (3.) and reengage in the initial position (4.), i.e. the handles must be in the bottom position and vertical.

When the handles are correctly engaged, it should not be possible to lift off the load plate.

8 Standard accessories

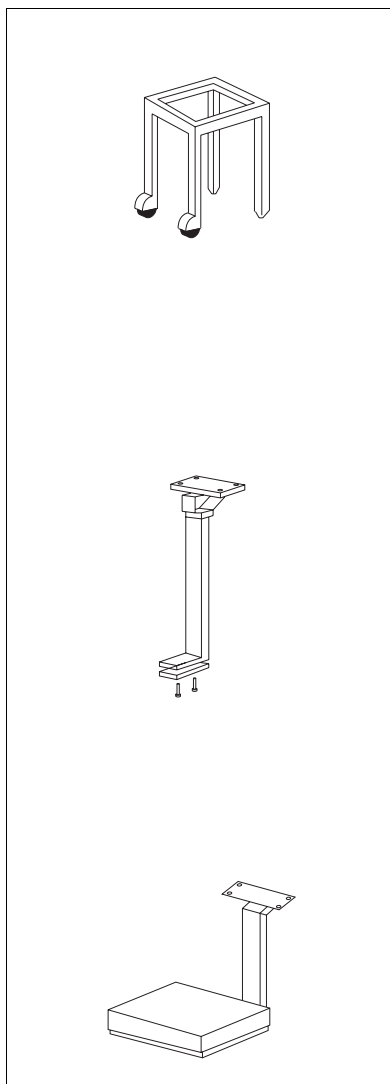

Order No.

Stand

Rigid frame construction
2 feet with casters
1 fixed foot with screw adjustment
height approx. 560 mm

for KB60

powder-coated/enamelled	00 503 631
stainless steel	00 503 632

for KCC150, KCC300

powder-coated/enamelled	00 504 853
stainless steel	00 504 854

Pillar support

for KB60, KCC150, KCC300
for mounting terminals on stand
incl. fastenings

for ID1 Plus, ID3s or ID7

powder-coated/enamelled	00 504 127
stainless steel	00 504 128

for IND690

stainless steel	22 011 986
-----------------	------------

for IND4x9

stainless steel	22 014 835
-----------------	------------

Scale stand

00 504 439

for KA15s, KA32s, KB60
for mounting ID1 Plus or ID3s
terminal on the weighing platform,
all stainless steel

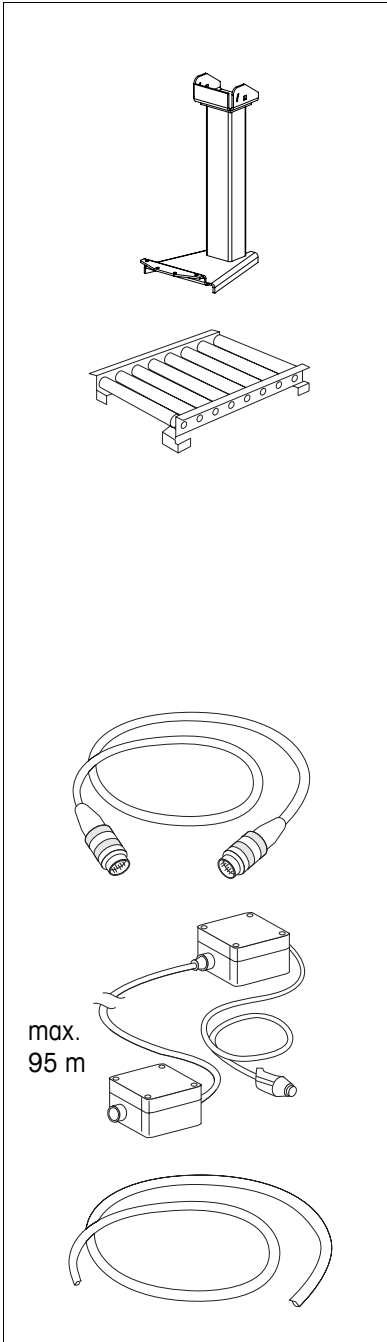

max.
95 m

Order No.

Scale stand

22 014 836

for KA..., KB60
for mounting IND4x9 terminal on
the weighing platform,
330 mm high, all stainless steel

Roller track

Steel-clad rollers with rust
protection, for dry surroundings
lengthwise motion
for KB60 (8 rollers) 00 503 640
for KCC150, KCC300 (9 rollers) 00 504 852

Steel-clad rollers with rust
protection, for wet surroundings
lengthwise motion
for KB60 (8 rollers) 22 001 647
for KCC150, KCC300 (9 rollers) 22 001 648

Extension cable

00 504 134

Length 10 m, connector at both
ends
for remote setup of ID terminal

Cable adapter kit for ID terminals 00 504 133

for infinite extension of connection
cable to 100 m
comprising two junction boxes
Box at terminal end with connection
cable of 2.5 m length

Special cable from the roll

00 504 177

used with adapter kit for ID
terminals for infinite extension of
connection cable to required length

9 Technical data of the measuring cell

Types	TBrick 6, TBrick 15, TBrick 32
Ignition protection type	II 3G Ex nA II T6 $-10\text{ °C} \leq T_a \leq +40\text{ °C}$ II 3D Ex tD A22 IP67 T 70 °C DMT 02 E 012 The following safety-related variables must be ensured by the connected weighing terminal:
	Supply circuit $U_{\max} \leq 20\text{ V DC}$
	Interface circuit $U_{\max, CL} \leq 27\text{ V DC}$ $I_{\max, CL} \leq 30\text{ mA}$ $U_{\max\text{ Diff, RS422}} \leq 10\text{ V DC}$
Power consumption	12 V DC $\pm 20\%$; 125 mA; 1.4 VA
IP protection type	IP67

10 Disposal



In accordance with the requirements of the European Directive 2002/96 EC about Waste Electrical and Electronic Equipment (WEEE) this equipment may not be disposed of in the household refuse.

This applies correspondingly for countries outside the EC in accordance with the applicable national regulations.

→ Please dispose of this product in accordance with the local regulations in a separate collection for electrical and electronic equipment.

Should you have any questions, please contact the responsible authorities or the dealer from whom you purchased this equipment.

If this equipment is passed on (for example for private or commercial/ industrial further use), this specification has to be passed on correspondingly as well.

Many thanks for your contribution to protecting the environment.

ServiceXXL

Tailored Services

METTLER TOLEDO products stand for highest quality and precision. Careful handling in accordance with these operating instructions as well as regular maintenance and inspection by our professional customer service ensure the long and reliable function and maintenance of value of your measuring instruments. Our experienced service team will be pleased to inform you about corresponding service agreements or calibration services.

Please register your new product under www.mt.com/productregistration, so that we can inform you about improvements, updates and further important information about your METTLER TOLEDO product.

nefton
Ζύγιση
Σήμανση
Συμμόρφωση

Νεύτων Τεχνολογίες ABEE

Γέρακα 113, Τ.Θ. 67934

15344 Γέρακας

Τηλ: 210 6654544

Fax: 210 6654545

marketing@nefton.gr

www.nefton.gr



22007212E

Subject to technical changes © Mettler-Toledo (Albstadt) GmbH 10/09 Printed in Germany 22007212E

Mettler-Toledo (Albstadt) GmbH

D-72458 Albstadt

Tel. ++49-7431-14 0, Fax ++49-7431-14 232

Internet: <http://www.mt.com>